

1.0 S02:A - Typical Radial Shiplap External Wall Corner Fixing Details: Plan View

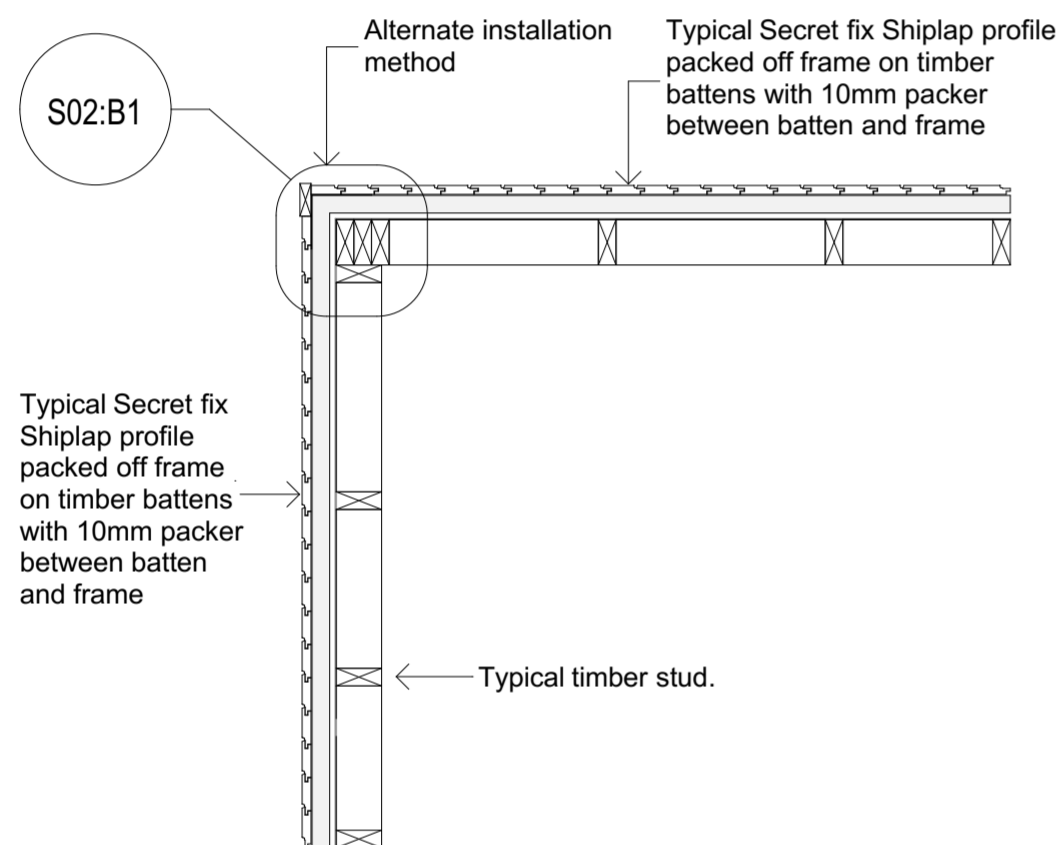

2.0 S02:B - Alternate Radial Shiplap External Wall Corner Fixing Details: Plan View

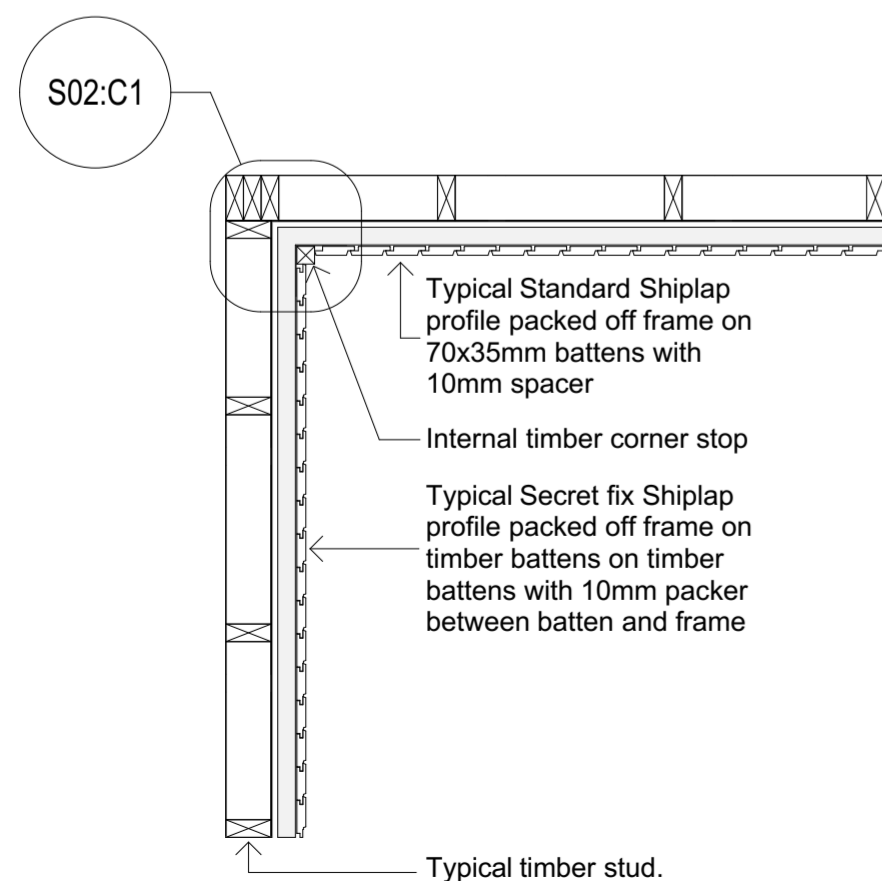

3.0 S02:C - Typical Radial Shiplap Internal Wall Corner Fixing Details: Plan View

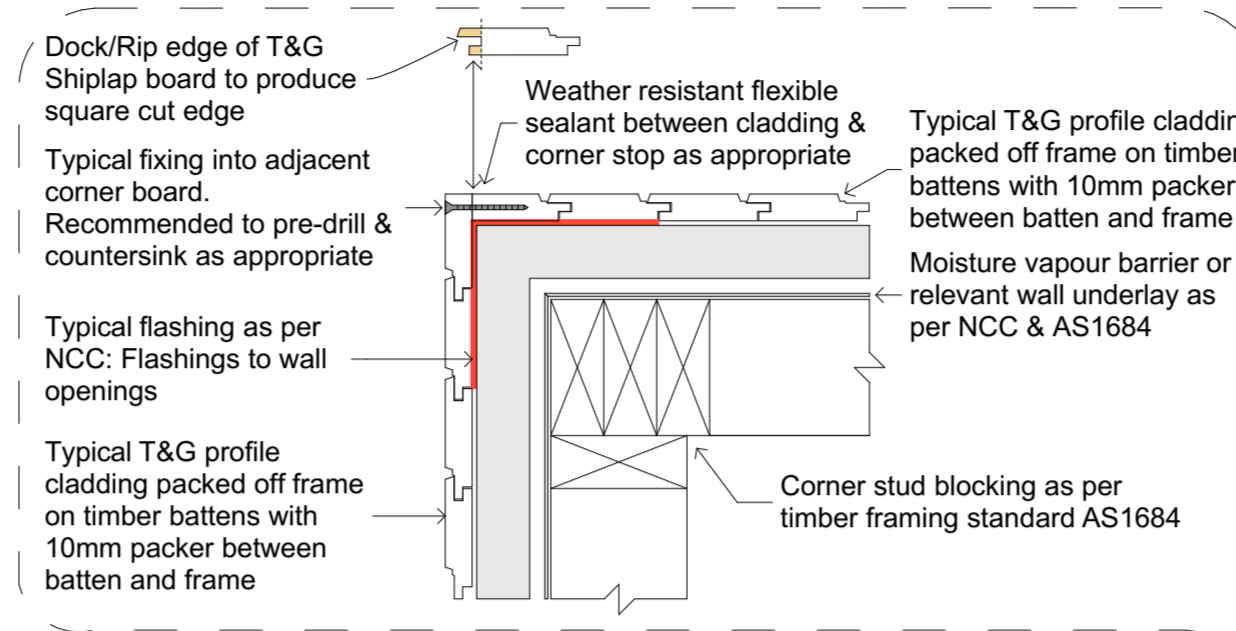

1.1 S02:A1 - Alternate Radial Shiplap External Wall Fixing Details

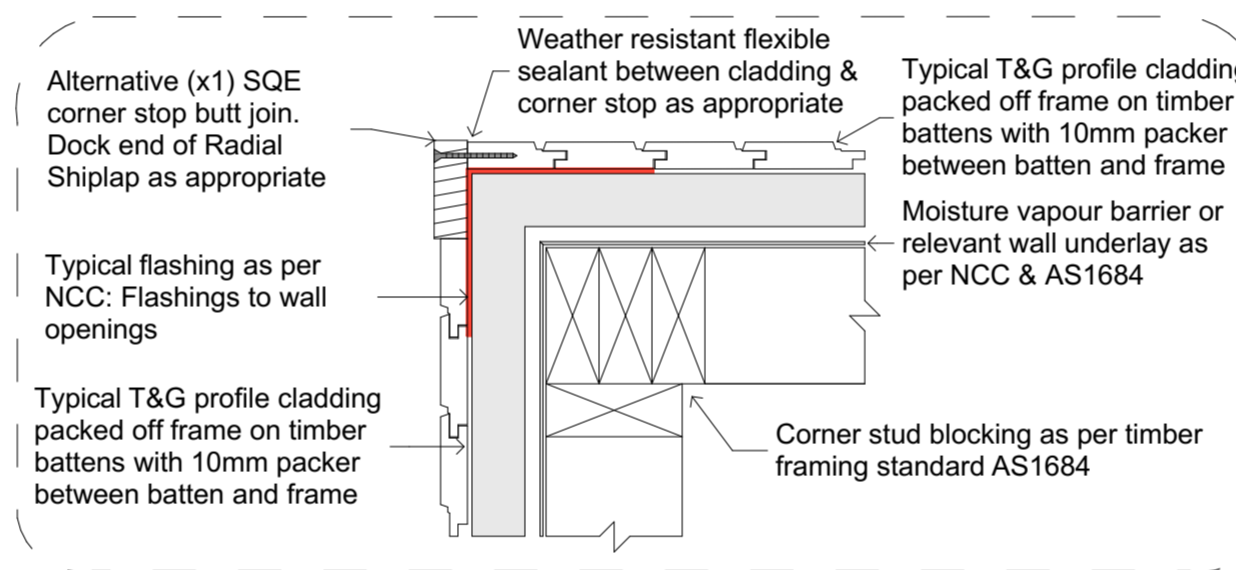

2.1 S02:B1 - Alternate Radial Shiplap External Wall Fixing Details

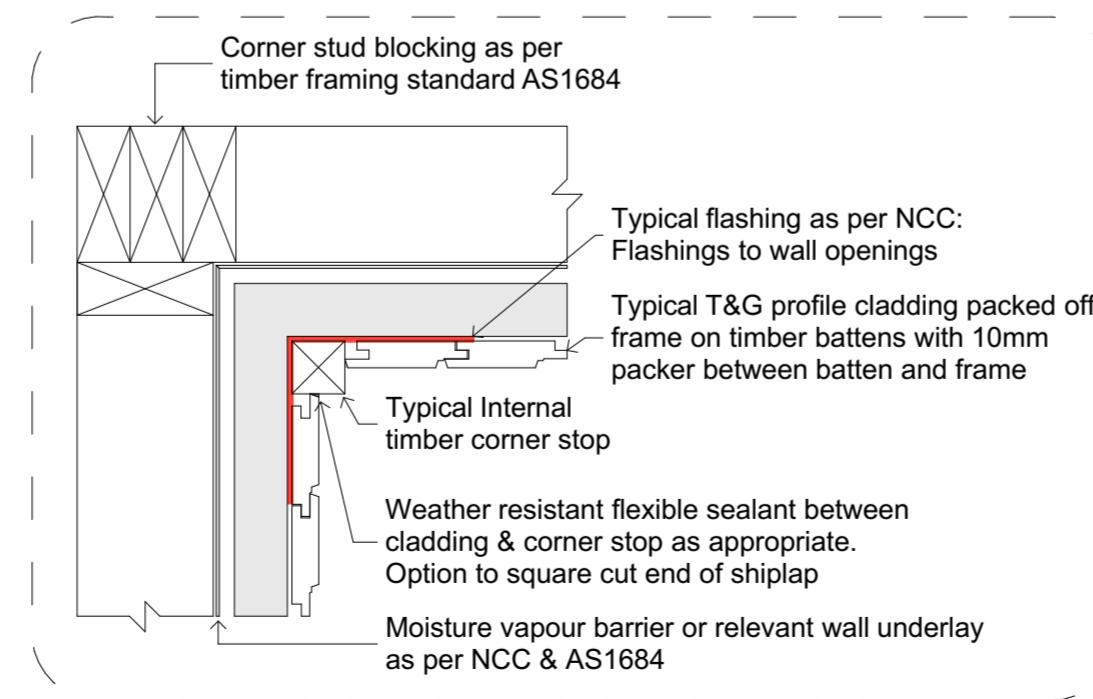

3.1 S02:C1 - Typical Radial Shiplap Internal Wall Corner Fixing Details

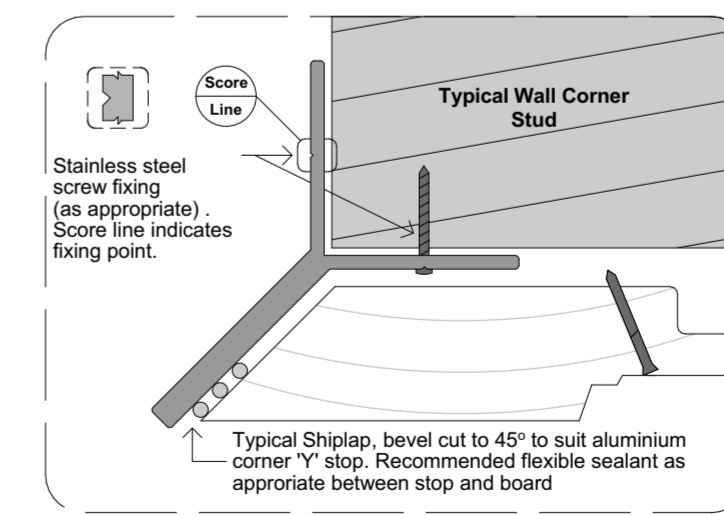

4.0 Typical Aluminium Y Section Corner Profile Or Folded Flashing

**GENERAL NOTES:**

1. Refer to Radial Timber installation guides for further installation information ([www.radialtimbers.com.au](http://www.radialtimbers.com.au))
2. Do not scale Drawings. If drawings are in question or discrepancy, the builder shall be responsible for obtaining clarification from the building designer and or building surveyor before continuing with construction.
3. All dimensions relating to existing conditions shall be field verified.
4. Where otherwise specified all products shall be installed according to Radial Timbers specifications. This applies not withstanding any relevant Building Act, Regulation, Building Code of Australia, Local Government Regulation/Requirement and Australian Standard.
5. All external timbers to be treated against weather exposure to current AS 1604 specifications or no less than durability Class 1 In-Ground/Class 2 Above Ground as per AS 5604 Timber Natural Durability Ratings.
6. All Residential timber framing, bracing & tie downs are to be in accordance to AS 1684 (Commercial construction specifications to be provided by Engineer).
7. Compliance with the relevant National Construction Code Of Australia (NCC) Volume 1 & or Volume 2 is mandatory (Not limited to) & the GUIDE TO STANDARDS & TOLERANCES.
8. Compliance with the NCC: **Timber Cladding & Flashings to wall openings**  
Openings in *external wall* cladding exposed to the weather must be flashed as per NCC requirements.
9. Compliance with the following Australian Standards is mandatory (Not limited to):  
  
AS 1684 TIMBER FRAMED CONSTRUCTION  
AS 5604 NATURAL TIMBER DURABILITY  
AS 3959 CONSTRUCTION IN BUSHFIRE AREAS  
AS 2796.1 TIMBER HARDWOOD - SAWN & MILLED PRODUCTS (PRODUCT SPECIFICATION)  
AS 2047 WINDOWS IN BUILDINGS  
AS 2870 RESIDENTIAL SLABS & FOOTINGS  
AS 2311 PAINTING OF BUILDINGS  
AS 3600 TERMITE MANAGEMENT  
AS 1170 STRUCTURAL DESIGN ACTIONS
10. All underground services (Sewer, Drainage, Gas, Electric, telecommunications, etc;) to be determined on site & from relevant authority records, prior to commencement of any construction.

DETAILS INDICATED MAY NOT ALIGN WITH SPECIFIC STRUCTURAL ELEMENTS AND ARE INDICATIVE OF HOW RADIAL TIMBER PRODUCTS ARE TO BE GENERALLY INSTALLED. THE BUILDER SHALL CHECK AND VERIFY ALL DIMENSIONS AND CONSTRUCTION METHODS WITH THE DESIGNER AND NOTIFY ALL ERRORS AND OMISSIONS TO THE DESIGNER. DRAWINGS ARE NOT TO BE USED FOR CONSTRUCTION UNTIL ISSUED BY THE DESIGNER FOR CONSTRUCTION. DO NOT SCALE DRAWINGS. USE FIGURED DIMENSIONS ONLY.



RADIAL TIMBER SALES  
12 PARK DRIVE,  
DANDENONG SOUTH,  
VICTORIA 3175  
PH: (03) 9768 2100  
EMAIL: [sales@radialtimbers.com.au](mailto:sales@radialtimbers.com.au)  
WEB: [www.radialtimbers.com.au](http://www.radialtimbers.com.au)

DRAWING NAME:  
Radial Shiplap External and Internal Corner Details

SCALE: A2 - Not To Scale DWG NO: S02  
DATE: 15/09/2022 REVISION: 7